



# DATASHEET APULN Specification V1.30

Ultra-low noise Microwave Signal Generators

100 kHz to 6, 12.75, 20, 26 and 40 GHz



**Document size:**

1 (one) title page  
17 (seventeen) content pages

## DEFINITIONS

The specifications in the following pages describe the warranted performance of the instrument for  $23 \pm 5$  °C after a 30-minute warm-up period

**Typical:** Expected mean values, not warranted performance

**Min and max:** Parameter range that is guaranteed by product design, and/or production tested. Warranted performance specifications include guard-bands to account for the expected statistical performance distribution, measurement uncertainties, and changes in performance due to environmental conditions.

## INTRODUCTION



### **Ultra-low noise Microwave Signal Generator 100 kHz to 6, 12.75, 20, 26 and 40 GHz**

The APULN is an ultra-low-noise and fast-switching microwave signal generator covering a continuous frequency range from 100 kHz up to 6, 12.75, 20 GHz, 26 or 40 GHz, respectively, with a lower than 0.001 Hz resolution.

The APULN provide an accurately levelled output power range and high spurious suppression. Advanced frequency synthesis combines fastest switching speeds with ultra-low SSB phase noise and fine frequency and power resolution.

The APULN supports analog modulation including pulse and chirp modulation with programmable patterns.

The APULN allows fast digital sweeps including flexible list sweeps, where frequency, power and dwell times can be set individually. A flexible triggering system simplifies synchronization within test environments.

All APULN operate with ultra-stable temperature compensated frequency reference (OCXO) to ensure minimal drift and can be phase-locked to an external reference.

The compact unit allows full front panel control via touch panel display.

# FACTS & FIGURES & SPECIFICATIONS

## Signal Specifications

PARAMETER	MIN	TYPICAL	MAX	NOTE
<b>Frequency Range</b>	100 kHz		6 GHz	APULN6
	100 kHz		12.75 GHz	APULN12
	100 kHz		20 GHz	APULN20
	100 kHz		26 GHz	APULN26
	100 kHz		40 GHz	APULN40
Resolution		0.001 Hz		
<b>Phase Resolution</b>		0.01 deg		
<b>Switching Speed</b>		1.5 ms		Valid signal after SCPI received
SCPI CW mode		500 μs		
Sweep / List Mode		20 μs		
<b>SSB Phase noise at 1 GHz</b>				Option FS (see also plots / tables)
at 10 Hz from carrier		-87 dBc/Hz		Option LN
at 1 kHz from carrier		-100 dBc/Hz		
at 20 kHz from carrier		-130 dBc/Hz		
at 100 kHz from carrier		-145 dBc/Hz		
<b>SSB Phase noise at 4 GHz</b>				
at 10 Hz from carrier		-74 dBc/Hz		Option LN
at 1 kHz from carrier		-90 dBc/Hz		
at 20 kHz from carrier		-121 dBc/Hz		
at 100 kHz from carrier		-133 dBc/Hz		
<b>SSB Phase noise at 10 GHz</b>				
at 10 Hz from carrier		-67 dBc/Hz		Option LN
at 1 kHz from carrier		-80 dBc/Hz		
at 20 kHz from carrier		-113 dBc/Hz		
at 100 kHz from carrier		-124 dBc/Hz		
<b>SSB Phase noise at 40 GHz</b>				
at 10 Hz from carrier		-55 dBc/Hz		Option LN
at 1 kHz from carrier		-68 dBc/Hz		
at 20 kHz from carrier		-101 dBc/Hz		
at 100 kHz from carrier		-112 dBc/Hz		
<b>Harmonics (at +5 dBm Pout, w/o PE4) at +15 dBm</b>		-40 dBc -35 dBc -55 dBc	-30 dBc -25 dBc -50 dBc	0.01 to 6 GHz >6GHz Option FILT, >1 GHz
<b>Sub-Harmonics</b>		-75 dBc -70 dBc -55 dBc		<5 GHz 5 - 20 GHz >20 GHz
<b>Non-Harmonic Spurious (&gt; 10 kHz offset)</b>		-90 dBc -92 dBc -90 dBc -84 dBc -80 dBc -70 dBc	-85 dBc -88 dBc -86 dBc -80 dBc -74 dBc -66 dBc	<1.2 GHz 1.2 - 2.5 GHz 2.5 - 5 GHz 5 - 10 GHz 10 - 20 GHz >20 GHz

PARAMETER	MIN	TYPICAL	MAX	NOTE
<b>Output power level</b>				
<10 MHz	-20 dBm		+18 dBm	
0.01 to 6 GHz	-20 dBm		+24 dBm	
6 to 12.75 GHz	-20 dBm		+23 dBm	
12.75 to 26 GHz	-20 dBm		+20 dBm	
26 to 40 GHz	-20 dBm		+18 dBm	
<b>Output power level (option PE4)</b>				
<10 MHz	-90 dBm		+18 dBm	
0.01 to 6 GHz	-90 dBm		+21 dBm	
6 to 12.75 GHz	-90 dBm		+20 dBm	
12.75 to 20 GHz	-80 dBm		+15 dBm	
20 to 40 GHz	-55 dBm		+10 dBm	
<b>Power Resolution</b>		0.01 dB		
<b>Power Level Uncertainty</b>				
<6 GHz		0.25 dB	0.8 dB 1.2 dB	-15 to +15 dBm -60 to -15 dBm or >15 dBm
6 to 12.75 GHz		0.3 dB	0.9 dB 1.3 dB	-15 to +15 dBm -60 to -15 dBm or >15 dBm
12.75 to 26 GHz		0.3 dB	1.0 dB 1.6 dB	-15 to +15 dBm -60 to -15 dBm or >15 dBm
26 to 40 GHz		0.4 dB	1.2 dB 2.5 dB	-15 to +15 dBm -60 to -15 dBm or >15 dBm
<b>Reverse Power Protection</b>				
DC Voltage			±10 V	
RF Power			30 dBm	
<b>Output impedance</b>		50 Ohms		
VSWR		1.4	1.8	



## Modulation Capabilities (Option MOD)

PARAMETER	MIN	TYPICAL	MAX	NOTE
<b>Pulse Modulation</b>				
Modulation source		Internal/ External		
External input amplitude	TTL			
Pulse rise/fall time		10 ns		
On/off ratio (high ON/OFF mode)		80 dB 75 dB	70 dB 65 dB	Pout > +10 dBm, f<18 GHz > 18 GHz
Pulse overshoot			10%	
Pulse delay		20 ns		
Pulse polarity		Normal, inverse		selectable
<b>Internal pulse generator</b>				
Repetition frequency (PRF)	0.1 Hz		50 MHz	= 1/T
Duty cycle	1 % to 99 % in 1% steps			within specified minimum pulse width
Minimum pulse settling range	30 ns 10 ns		20 s 20 s	Option FS
Pulse Pattern Modulation & Staggered PRF				Using internal pattern generator
Programmable pattern length	2		65536	
Duty cycle	0.05%		99.95%	
Pulse width resolution		5 ns		
Pulse period (T) accuracy		0.00005xT+ 3ns		
Pulse width accuracy		0.00005xT+ 5ns		
Pulse width resolution		5 ns		
Pulse jitter		2 ns	5 ns	
Polarity		selectable		
<b>Amplitude Modulation</b>				
Modulation source		Internal/ (External)		
Modulation Depth	0%		90%	
Deviation accuracy		2%	4%	1 kHz rate, 30% depth
Deviation resolution		1%		
Distortion (THD)			1%	1 kHz rate, 30% depth
Modulation rate	0.1 Hz		30 kHz	
Modulation waveforms	Sine			
<b>Chirped Pulse Modulation</b>				
Modulation source		Internal		Option FS & MOD
Chip span	1 Hz		3 %	of RF
Chip rate	1 Hz		100 kHz	
Pulse width	10 μs		1 sec	
Chip slope			0.5% / μs	of RF
Chip mode		Linear, exponential, up, down, bidirectional		
<b>PARAMETER</b>				
<b>MIN</b>				
<b>TYPICAL</b>				
<b>MAX</b>				
<b>NOTE</b>				
<b>Frequency Modulation</b>				
Modulation source		Internal/		

		(External)		
Maximum Frequency deviation (peak)	N · 200 MHz			< 1.25 GHz (N=1) 1.25 GHz to 2.5 GHz (N=0.125) 2.5 GHz to 5 GHz (N=0.25) 5 GHz to 10 GHz (N=0.5) 10 GHz to 20 GHz (N=1) 20 GHz to 40 GHz (N=2)
Deviation accuracy		0.50%	2%	
Distortion (THD)		< 1 %		1 kHz rate, 10 kHz deviation
Modulation rate	0.1 Hz		80 kHz	
Modulation waveforms	Sine			
<b>Phase Modulation</b>				
Modulation source		Internal/ (External)		
Phase deviation (peak)	0		300 · N · rad	
Deviation accuracy		0.50%	2%	
Modulation rate	0.1 Hz		80 kHz	
Modulation waveforms	Sine			
Distortion (THD)		< 1%		1 kHz rate & N x rad deviation

### Sweeping Capability, Sweep type: linear, logarithmic, random

PARAMETER	MIN	TYPICAL	MAX	NOTE
<b>Sweep Parameters</b>	Frequency, power, phase, list			
Step time ( $t_{step}$ )	500 $\mu$ s 20 $\mu$ s		19998 s 19998 s	Option FS
Settling time ( $t_{inv}$ )			15 $\mu$ s	To stabilize phase and amplitude, depends on frequency step
Trigger latency ( $t_{de}$ )			1 $\mu$ s	Time from trigger to initiate signal transient
Time resolution		5 ns		
Timing accuracy per point		5 ns		

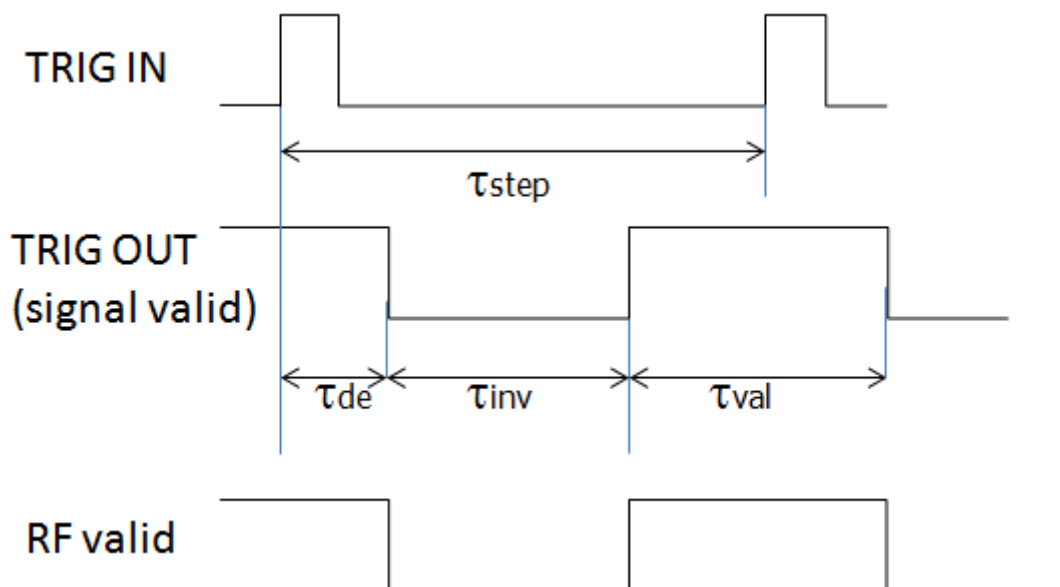

## Frequency Reference

PARAMETER	MIN	TYPICAL	MAX	NOTE
<b>Internal reference frequency</b>		100 MHz 10 MHz		Option LN
Temperature stability			±100 ppb ±30 ppb	0 to 50 degC Option LN
Aging 1st year			1 ppm 0.3 ppm	Option LN
Aging per day			5 ppb 0.5 ppb	after 30 days operations Option LN
Warm-up time		5 min		
Output of internal reference		100 MHz		
		10/100 MHz		Option LN
Output power		0 dBm		
Output impedance		50 Ohms		
<b>Bypass Internal reference Input</b>		100 MHz		High phase synchronous mode
<b>Phase Lock to External Reference</b>		10 MHz integer MHz 100 MHz	250	Option VREF
Bypass Mode	5			
<b>Reference input level</b>				
10 MHz or 1-250 MHz	-5 dBm	0 dBm	+10 dBm	
100 MHz	5 dBm		+15 dBm	
<b>Lock Range</b>				
10 MHz or 1-250 MHz			±1.5 ppm	
100 MHz			>100 ppm	
<b>Reference input impedance</b>		50 Ohms		

## Trigger (TRIG IN): Input is TRIG IN at front panel

PARAMETER	MIN	TYPICAL	MAX	NOTE
<b>Trigger Types</b>	Continuous, single (point), gated, gated direction			
<b>Trigger Source</b>	external, bus (LAN, USB)			
<b>Trigger Modes</b>	Continuous free run, trigger and run, reset and run			
Trigger latency		5 ns		
Trigger uncertainty		10 ns		
External Trigger delay	50 ns		40 s	settable
External Delay Resolution		5 ns		
<b>Trigger Modulo</b>	1		255	Execute only on Nth trigger event
<b>Trigger Polarity</b>	Rising, falling			

# TYPICAL PERFORMANCE CURVES

## SSB Phase Noise Performance with option LN

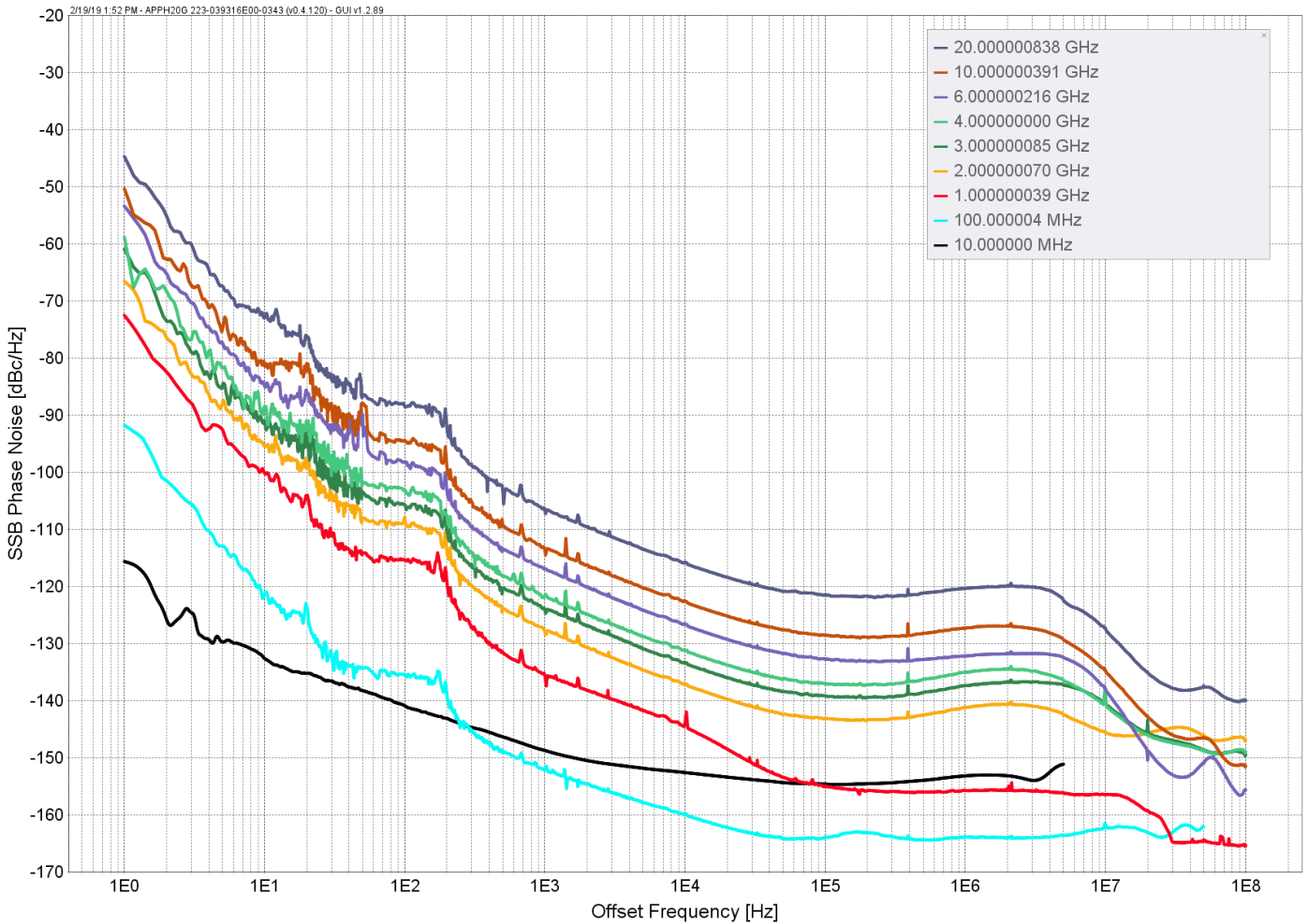

**Typical SSB Phase Noise [dBc/Hz], CW, level = 20 dBm, Option LN**

Offset → RF ↓	1 Hz	10 Hz	100 Hz	1 kHz	10 kHz	100 kHz	1 MHz	floor
10 MHz	-116	-133	-141	-149	-153	-155	-154	-155
100 MHz	-96	-121	-137	-148	-157	-162	-162	-162
1 GHz	-76	-100	-120	-132	-142	-153	-156	-165
2 GHz	-70	-94	-114	-125	-135	-143	-143	-155
3 GHz	-66	-90	-110	-122	-132	-139	-139	-151
4 GHz	-64	-88	-108	-118	-129	-137	-137	-151
6 GHz	-60	-84	-104	-115	-124	-132	-133	-151
10 GHz	-56	-80	-100	-111	-121	-129	-129	-151
20 GHz	-50	-74	-94	-105	-116	-123	-123	-150



## SSB Phase Noise Performance, without option LN

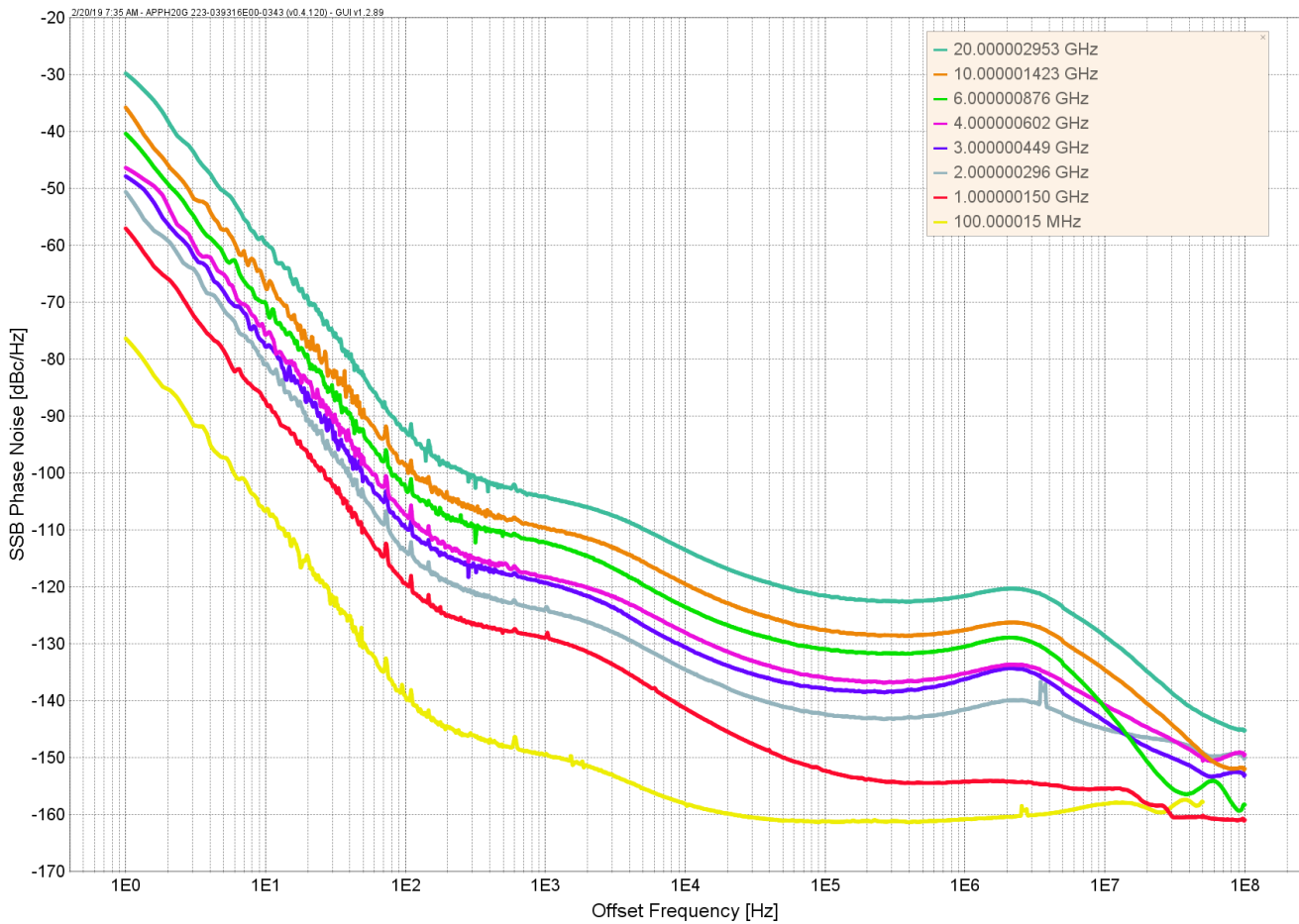

Typical SSB Phase Noise [dBc/Hz], CW, level = 20 dBm, without option LN

Offset → RF ↓	1 Hz	10 Hz	100 Hz	1 kHz	10 kHz	100 kHz	1 MHz	floor
10 MHz	No value?	No value?	No value?	-149	-153	-155	-154	-155
100 MHz	-76	-108	-140	-148	-157	-162	-162	-162
1 GHz	-57	-88	-120	-132	-142	-153	-156	-165
2 GHz	-51	-82	-114	-125	-135	-143	-143	-155
3 GHz	-47	-78	-110	-122	-132	-139	-139	-151
4 GHz	-45	-76	-108	-118	-129	-137	-137	-151
6 GHz	-41	-72	-104	-115	-124	-132	-133	-151
10 GHz	-37	-68	-100	-111	-121	-129	-129	-151
20 GHz	-31	-62	-94	-105	-116	-123	-123	-150

## Output Power 0.01 to 20 GHz (APULN20)

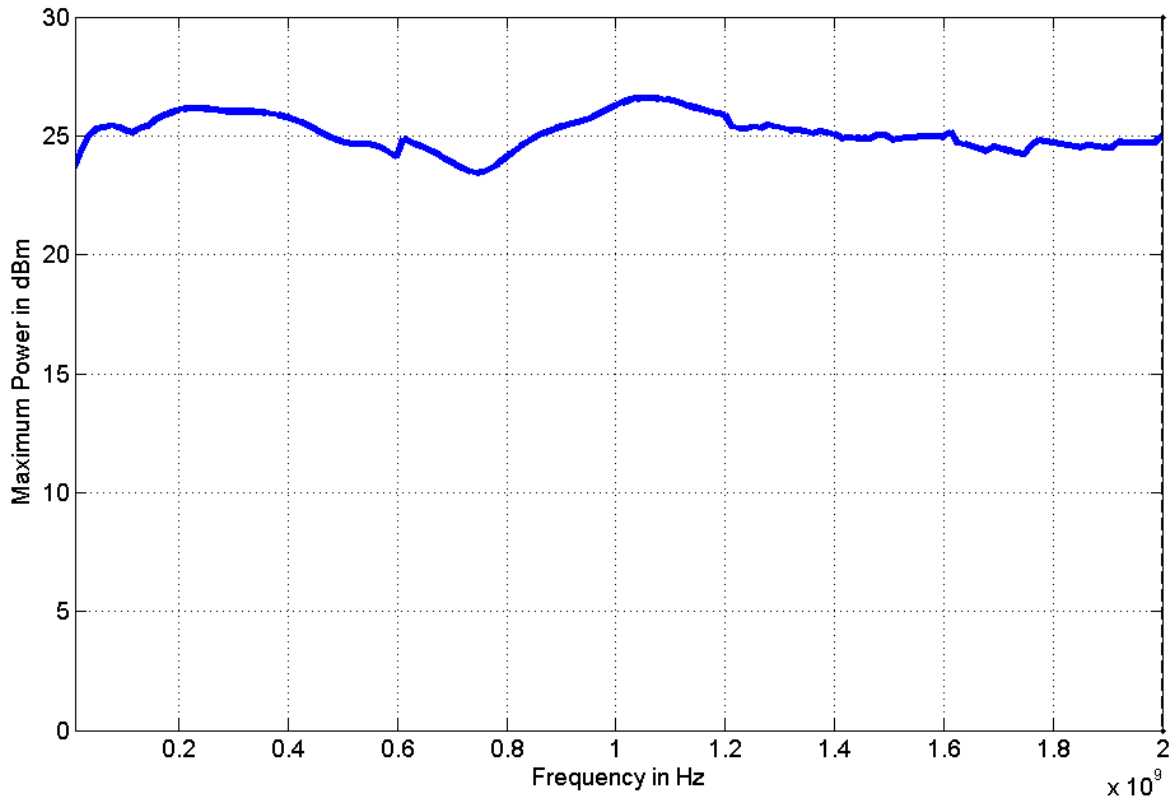

## Min & Max Output Power 0.01 to 40 GHz (APULN40)

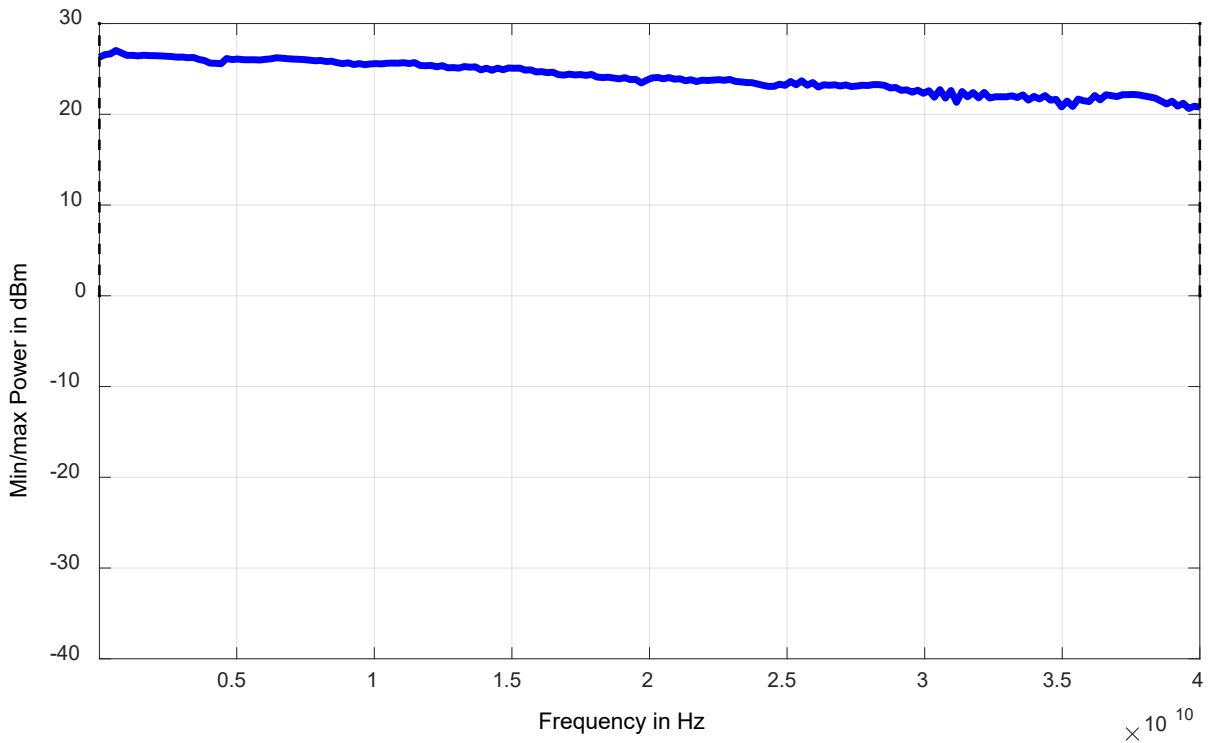

## Max Output Power 0.01 to 20 GHz (APULN20 with option PE4)

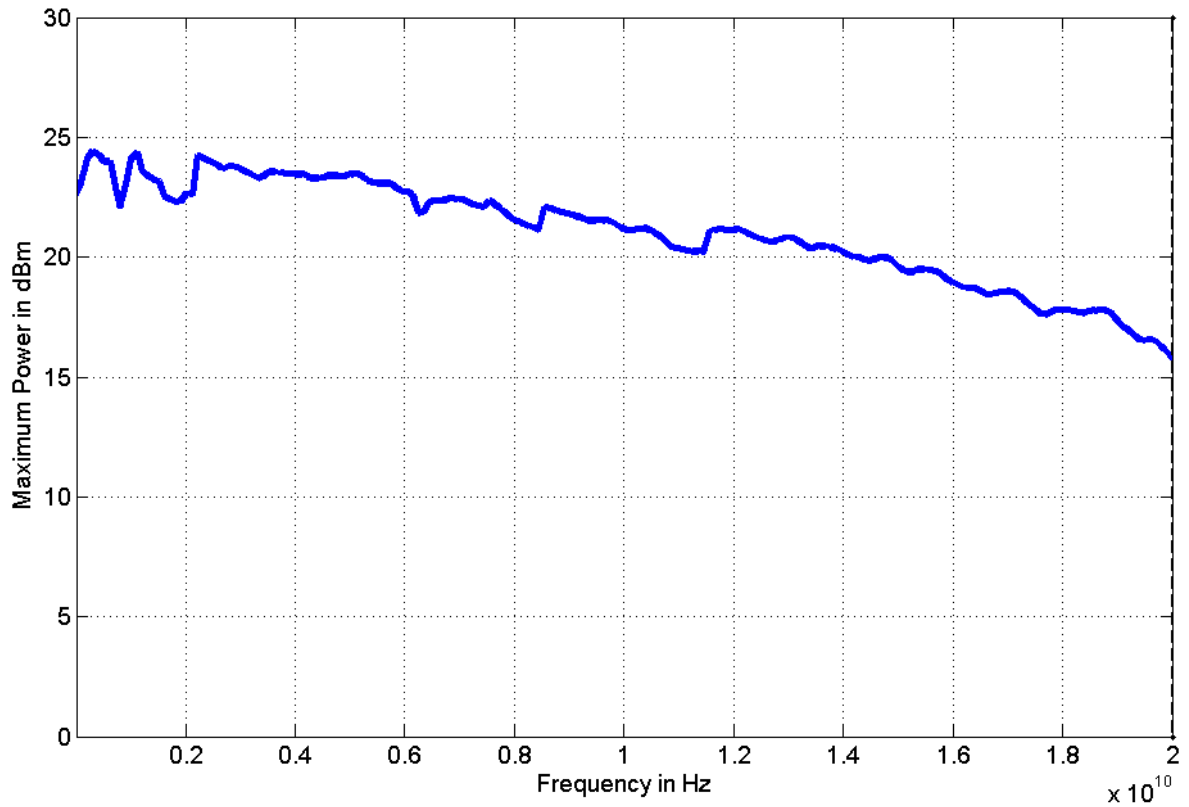

## Harmonics (2nd, 3rd at P=+10 dBm)

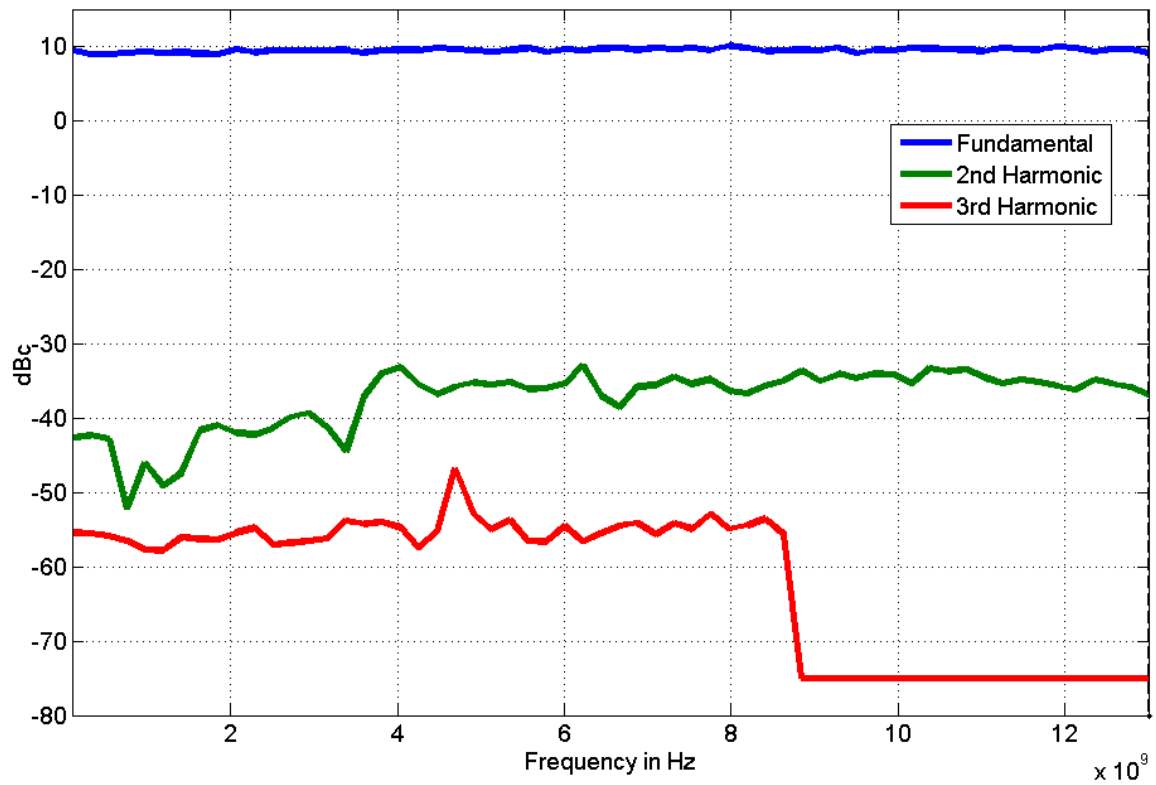

## Typical Frequency Response 0 to 20 GHz at different power levels (APULN20)

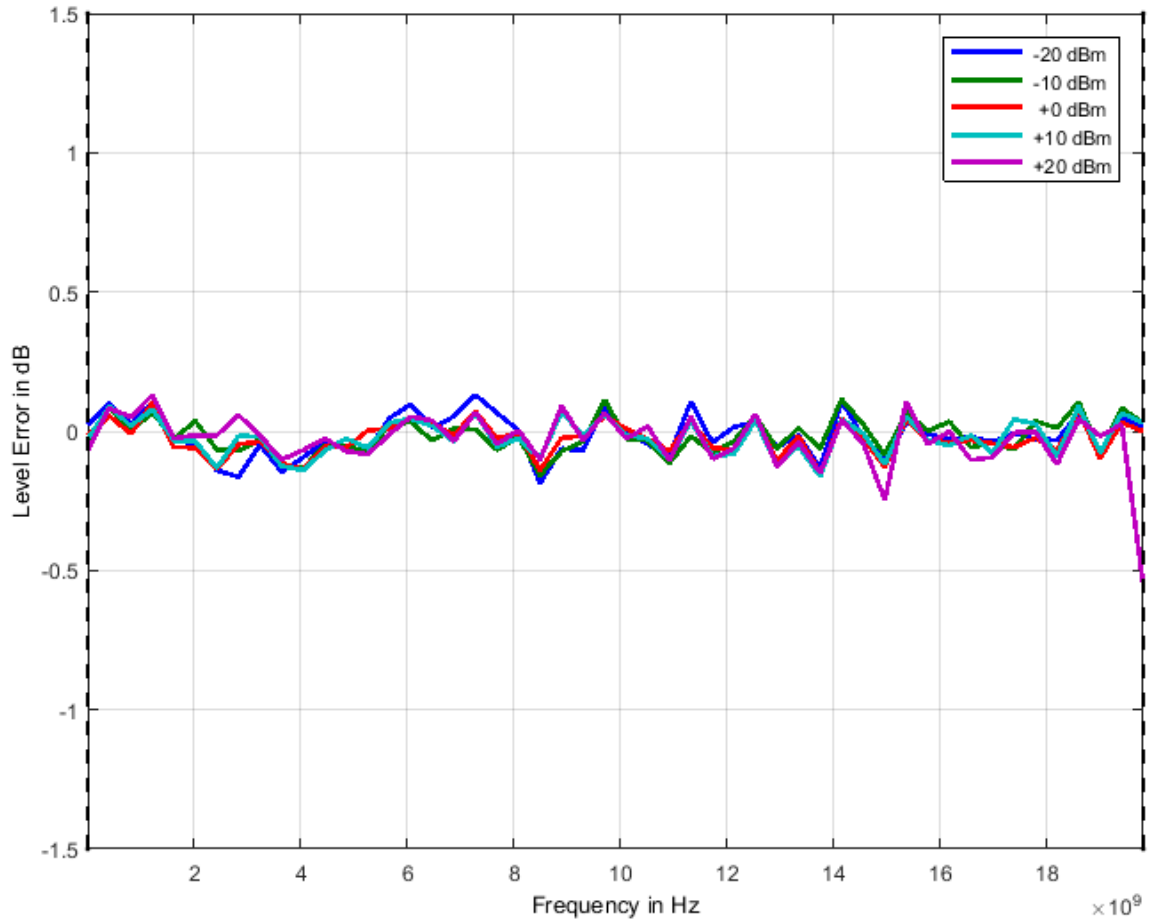

## Typical Output Power Linearity (APULN40)

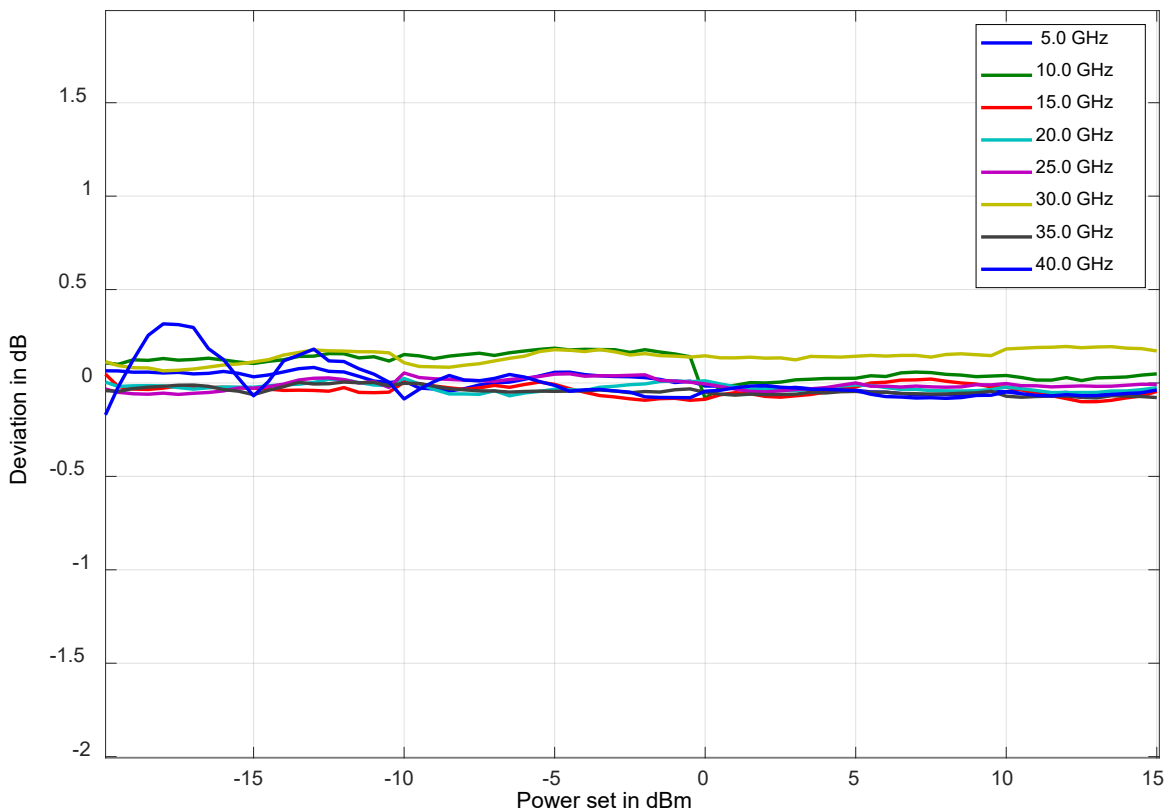

**Typical VSWR (APULN20)**

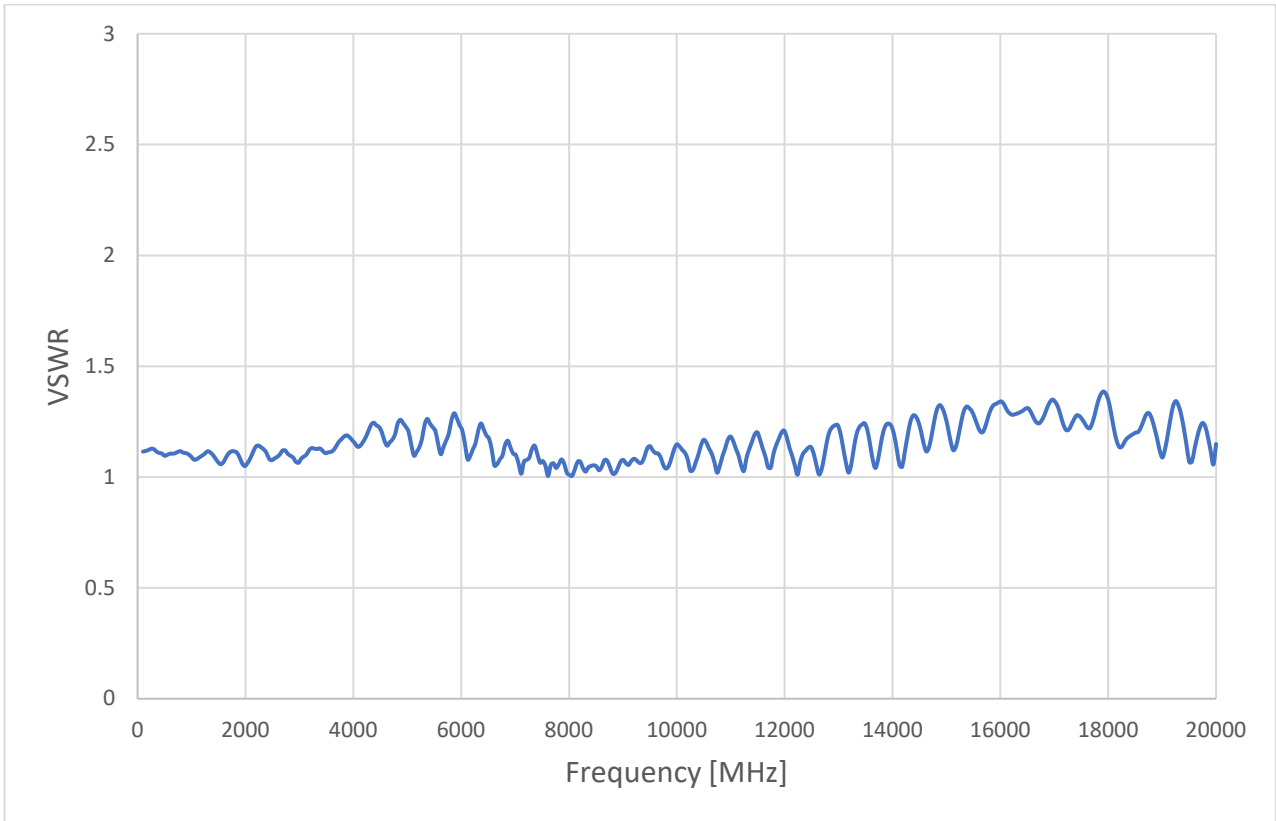

**Internal Pulse Modulation (10 GHz, 40ns period, 15 ns pulse width)**

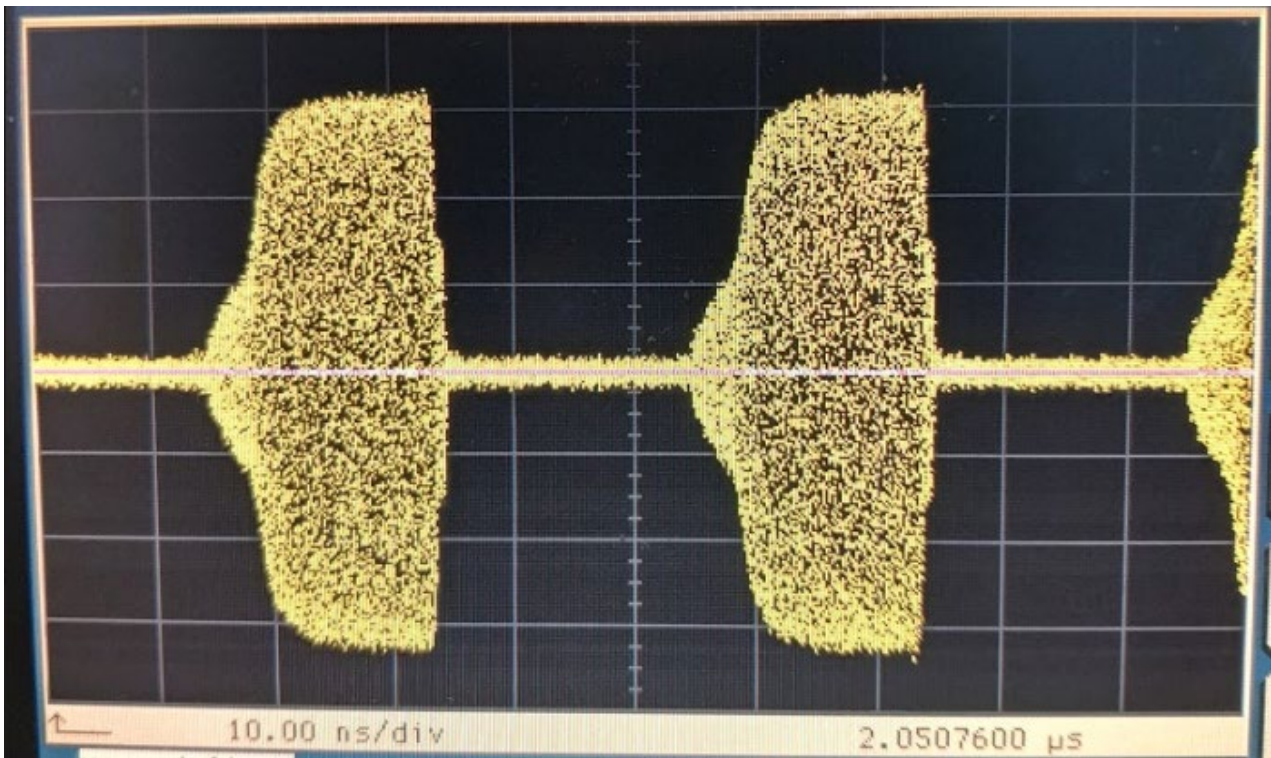

Internal Pulse Modulation (38.8 GHz, 15ns period, 7 ns pulse width)

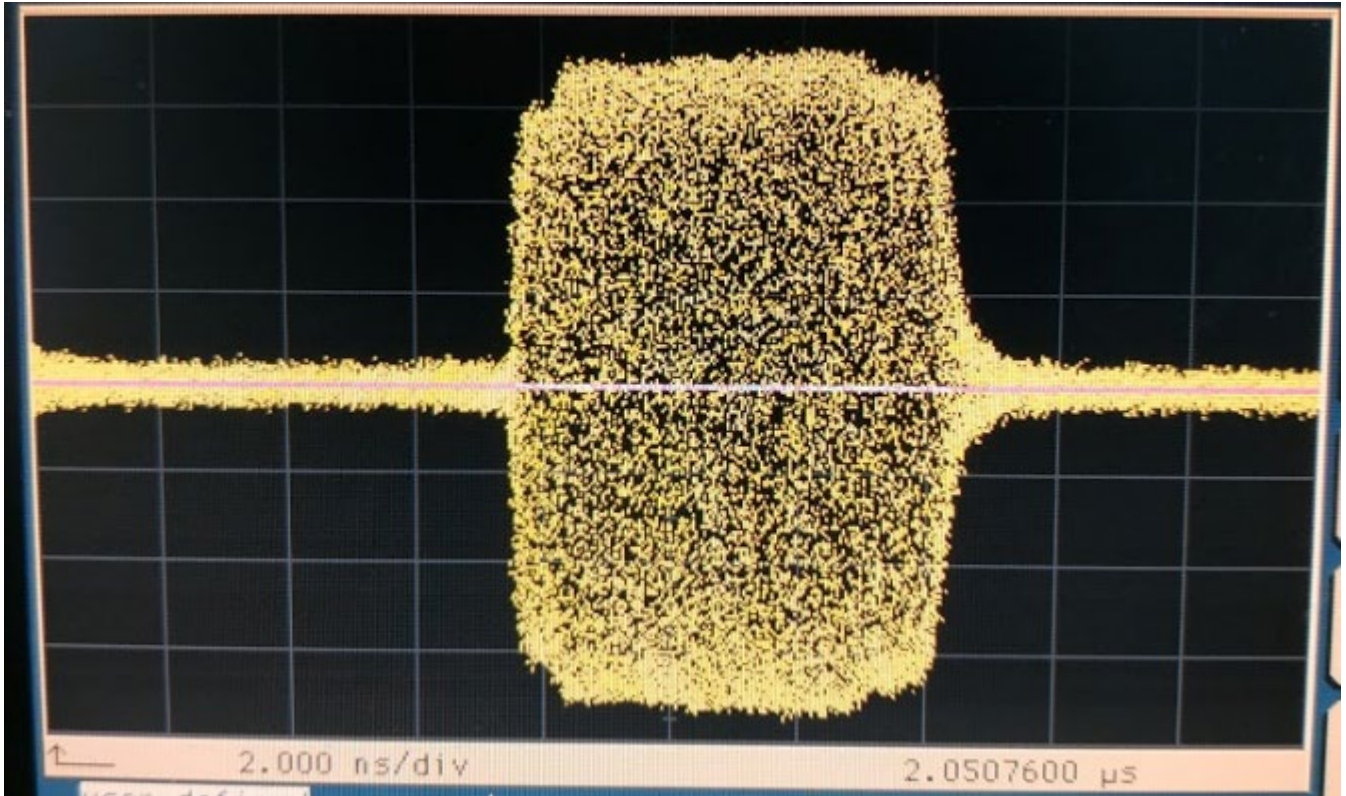

# CONNECTORS, IOS

## Front panel:

1. RF output:

APULN40: K (2.92 mm) female

APULN06,12,2026: SMA female

2. Rotary knob



## Rear panel:

1. TRIG IN: Trigger input: BNC female

2. TRIG OUT: Trigger output: BNC female

3. REF OUT: External reference input: BNC female

4. REF IN: Internal reference output: BNC female

5. MOD IN modulation input for AM/FM/PM: BNC female

6. PULSE IN: Pulse modulation input: BNC female

7. LAN connection: RJ-45

8. USB 2.0 host and device

9. GPIB: IEEE-488.2, 1987 with listen and talk (optional)

10. DC Power plug (24V, 3 A)

11. DC power switch

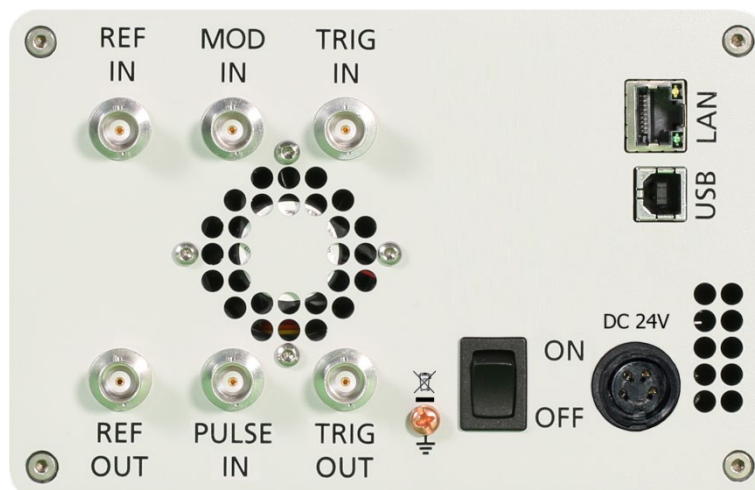

## ORDERING INFORMATION



HOST MODEL	PRODUCT	DESCRIPTION
APULN06	APULN06	100 kHz – 6 GHz
APULN12	APULN12	100 kHz – 12.75 GHz
APULN20	APULN20	100 kHz – 20 GHz
APULN26	APULN26	100 kHz – 26 GHz
APULN40	APULN40	100 kHz – 40 GHz
APULNXX	<b>Option LN</b>	Enhanced close in phase noise & frequency stability
APULNXX	<b>Option FS</b>	Ultra-fast switching speed
APULNXX	<b>Option MOD</b>	Analog modulation
APULNXX	<b>Option FILT</b>	Enhanced harmonic rejection
APULNXX	<b>Option VREF</b>	Variable External Reference
APULN6/12	<b>Option PE4-6/12</b>	Electrical step attenuator (6 & 12 GHz version)
APULN20/26	<b>Option PE4-20/26</b>	Electrical step attenuator (20 & 26 GHz version)
APULN40	<b>Option PE4-40</b>	Electrical step attenuator (40 GHz version)
APULNXX	<b>Option EB</b>	External power bank
APULNXX	<b>Option GPIB</b>	GPIB interface
APULNXX	<b>Option LH</b>	Desktop housing with color touch display
APULNXX	<b>Option 1URM</b>	19" 1HU rack enclosure
APULNXX	<b>Option REAR</b>	Move output to the rear
APULNXX	<b>Option FLASH</b>	MicroSD card slot for removable microSD memory
APULNXX	<b>Option WE</b>	One year warranty extension
APULNXX	<b>Option ReCal</b>	Recalibration with test data



## GENERAL CHARACTERISTICS

### Remote programming interfaces

Ethernet 100BaseT LAN interface,  
USB 2.0 host & device  
GPIB (IEEE-488.2,1987) with listen and talk (optional)  
Control language SCPI Version 1999.0

**Power requirements** 24V ± 3.0 VDC; 25 W maximum

**Mains adapter supplied:** 100-240 VAC in/ 24 V 4.0 A DC out

**Environmental** (Levels similar to MIL-PRF-28800F Class 3/4)

Environmental stress Samples of this product have been type tested to be robust against the environmental stresses of storage, transportation, and end-use; those stresses to temperature, humidity, shock, vibration, altitude, and power line conditions.

**Operating temperature range** 0 to 45 °C

**Storage temperature range** -40 to 70 °C

**Operating and storage altitude** up to 15,000 feet (4600 m)



notice

EMC complies and EMC regulations and directives for emission and immunity to interference (EN 61326-1 Industrial, EN/IEC 61326-2-1).

**Safety** complies with applicable Safety regulation in line with IEC/EN 61010-1

This product complies with directive 2011/65/EU

**Weight** 2.5 kg (6 lbs) net, ≤ 4 kg (8 lb.) shipping

**Dimensions** 106 mm H x 172 mm W x 290 mm L (incl. connectors) [4.21 in H x 6.77 in W x 11.42 in L]

**Recommended calibration cycle** 24 months



### Document History

Version/Status	Date	Author	Notes
V123	2019-02-28	jk	New layout
V124	2019-03-21	jk	Min. Pulse width w. option FS
V125	2019-10-1	jk	Pulsed chirps w. option FS
V126	2019-10-21	jk	Max power settings revised
V130	2020-1-26	jk	Option FILT added

### AnaPico Ltd. of Switzerland

Europastrasse 9  
8152 Glattbrugg  
Switzerland

Phone +41 44 515 55 01  
Fax +41 44 440 00 50  
Email sales@anapico.com

www.anapico.com  
www.anapico.com/downloads/

# NOTES

---

---

---

---

---

---

---

---

---

---

---

---

---

---

---

---

---

---

---

---

---

---

---

---

---

---

---

---

---

---